

4664

Power Tube

UHF High Power Tetrode Amplifier Tube

- 3.0 Megawatt Peak Power Output
- All Electrodes Liquid Cooled
- Ceramic-Metal Construction
- Matrix-Type Filamentary Cathode
- Low Input Capacitance
- Low Grid No. 1 inductance
- Integral Bypass, Grid No. 2 to Cathode

The BURLE 4664 is designed specifically for use in high-power, long-range search radar. Because of its low noise and high linearity, it is also useful in other high power pulsed amplifier service.

The 4664 is a liquid-cooled large-power, metal-ceramic tube rated for use at frequencies primarily between 200 and 608 MHz. The tube features a matrix-type, oxide impregnated filamentary cathode for high emission, long life and economical operation.

The mechanical structure of the tube is designed for low input capacity and low grid inductance. It employs a symmetrical array of unit electro-optical systems surrounding a centrally located anode. Integral capacitors effectively bypass the grid No. 2 to the cathode. Coolant courses to all the electrodes assure adequate thermal control of the tube structure.

The tube is designed to be used with the model AJ2201 Coaxial Coolant Separator or the model AJ2290 Threaded Tube Coolant Separator. The AJ2190 provides very efficient anode cooling and maximum allowable anode dissipation. These units are interchangeable between tubes and must be ordered separately.

This data sheet gives application information unique to the BURLE 4664. General information, covering the installation and operation of this tube type, is given in TP-105 "Application Guide for Power Tubes". Close attention to the instructions contained therein will assure longer tube life, safer operation, less equipment downtime and fewer tube handling accidents.

For further information or application assistance on this device, contact BURLE Applications Engineering, 1000 New Holland Avenue, Lancaster, PA 17601-5688.

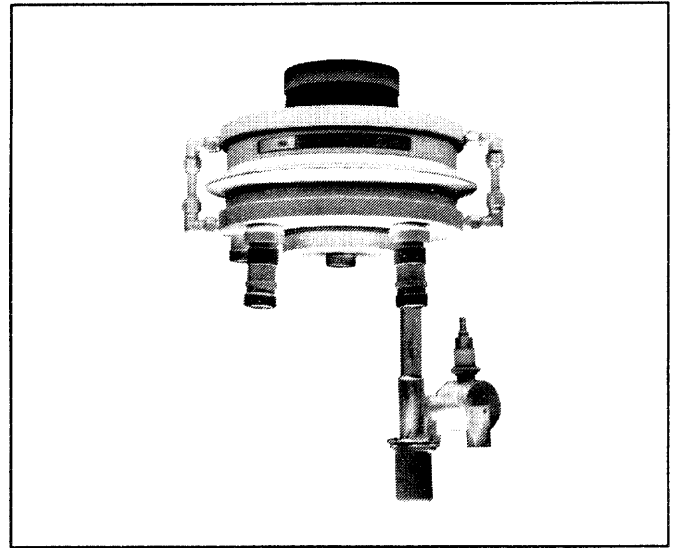

GENERAL DATA

Electrical

Cathode:

Type	Multistrand Filamentary Oxide-Impregnated Matrix
Voltage ¹ (DC or 60 Hz AC):	
Maximum	1.05 V
Typical	0.95 V
Minimum	0.90 V

Current:

Typical at 0.95 V AC	825 A
Maximum even momentarily	900 A

Warm-up Time:

Minimum to reach filament voltage	3.0 s
Minimum at filament voltage before applying other voltages90 s

Direct Interelectrode Capacitances

Grid No. 1 to anode	0.4 pF
Grid No. 1 to grid No. 2 and cathode	500 pF
Plate to grid No. 2 and cathode	30 pF
Grid No. 2 to cathode (including integral bypass capacitor)	13000 pF

Mechanical

Operating attitude	Tube axis vertical (either end up)
Maximum Overall Height	355.6 mm (14.0 in)
Maximum Diameter	285.8 mm (11.25 in)
Weight	17 kg (38 lb)
Terminal Connections	See Dimensional Outline

Thermal

Maximum Ceramic-Insulator Temperature	150 °C
Maximum Metal Surface Temperature	100 °C
Minimum Storage Temperature ²	-65 °C
Maximum External Gas Pressure ³ (absolute)	60 psi (4.1 atmospheres)

WARNING - PERSONAL SAFETY HAZARDS

Hazardous Material Content - Exposure to hazardous material would normally not occur in the ordinary use of this product. However, certain parts and components in this product may contain small amounts of materials that are considered by certain governmental bodies as having potential harmful effects. Therefore, please follow manufacturer's instructions in handling and using this product; refer servicing to an authorized service representative; and dispose of this product in accordance with all applicable environmental laws and regulations.

Radio Frequency Radiation - This device, in operation, produces radio frequency radiation which may be harmful to persons.

Thermal - This device may have exposed surfaces heated to high temperatures during operation creating thermal hazards. Touching these surfaces during or immediately following operation can cause burns. Sufficient time for cool down should be allowed before handling.

X-Ray Warning - This device, in operation, can produce x-rays which may constitute a health hazard unless the device is adequately shielded for radiation.

High Voltage - Although the user of this product is normally protected from the high voltage hazard by the equipment design, the voltages applied to this unit in normal operation are hazardous. High voltage safety precautions must be followed. Equipment caution labels and safety features must not be disregarded.

Cooling Requirements

Liquid Cooling:

The tube is designed and rated for water cooling supplied to the anode, insulated filament block, the uninsulated filament block and to the grids No.1 and No.2. The liquid flow to all electrodes must start before any voltages are applied and should continue for sometime after the voltages are removed. It is recommended that all power supplies be interlocked with the liquid flow through each of the coolant courses to insure against damage in case of failure of adequate liquid flow.

Specifications:

Maximum Liquid Pressure at Any Inlet (Gauge).....	100	psi
	690	kPa
Maximum Liquid Temperature at Any Outlet	70	°C
Minimum Resistivity of Liquid (Water at 25 °C)	1.0	megohm/cm

Coolant Flow and Pressure

The flow and differential pressure requirements for cooling the anode are given in **Figure 1**. Cooling requirements for the other electrodes are as follows:

Coolant Course	Flow				Max Pressure Differential ⁴	
	Min. gpm	cc/s	Typ. gpm	cc/s	psi	kPa ²
Insulated Fil.	0.5	31	0.8	51	8	55
Uninsulated Fil.	0.5	31	0.8	51	8	55
Grid No.1	0.5	31	0.8	51	6	41
Grid No.2	0.5	31	0.8	51	8	55

Air Cooling:

It is important that the temperature of all external parts of the tube be held within the specific maximum value. Forced-air cooling of the ceramic insulators and the adjacent contact areas may be required if the tube is used in a confined space without free circulation of air. Under such conditions a sufficient quantity of air should be directed across the ceramic insulators and adjacent terminal areas to limit their maximum temperature to the value specified. It is recommended that the air flow be interlocked with all power supplies to insure against tube damage in case of failure of an adequate flow of air.

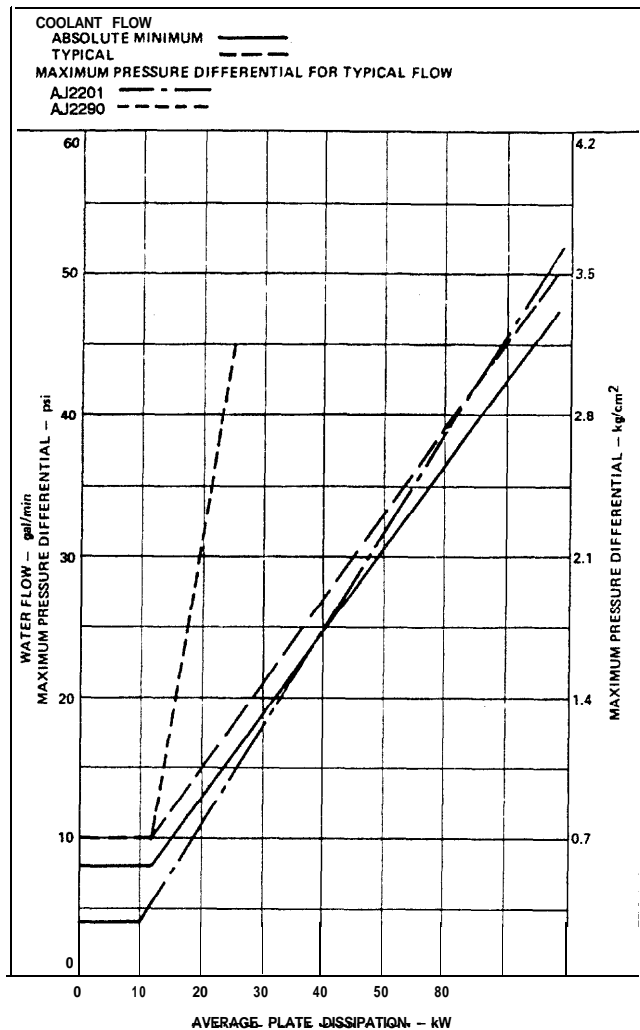

Figure 1: Plate Coolant Specifications

TYPICAL RATINGS AND PERFORMANCE⁵

Pulsed RF Amplifier

Maximum Ratings, Absolute-Maximum Values

For frequencies from 200 to 650 MHz and a maximum "ON" time of 25 in any 5000 microsecond interval.

Peak Pulsed DC Plate Voltage ⁵	45,000	V
Peak Pulsed DC Grid No.2 Voltage ^{6,7}	2,250	V
DC Grid No.1 Voltage	-400	V
Peak Pulsed DC Plate Current	150	A
Peak Pulsed DC Grid No.2 Current	30	A
Peak Rectified Grid No.1 Current.....	30	A
DC Plate Current.....	0.80	A
DC Grid No.2 Current	0.15	A
DC Grid No.1 Current	0.15	A
Average Plate Dissipation	50,000	W

Typical Plate-Pulsed Operation

In Class B service at 540 MHz with a rectangular waveshape pulse, a pulse width of 20 and duty factor of 0.0036.

Peak Pulsed DC Plate Voltage	36,000	V
Peak Pulsed DC Grid No.2 Voltage.....	2,200	V
DC Grid No.1 Voltage ^{8,9}	-280	V
Peak Pulsed DC Plate Current	115	A
Peak Pulsed DC Grid No.2 Current.....	12	A
Peak Rectified Grid No.1 Current.....	4	A
DC Plate Current	0.41	A
DC Grid No.2 Current	0.04	A
DC Grid No.1 Current	0.01	A
Peak RF Drive Power	10,000	W
Useful Peak Power Output (Approx.)	2,100,000	W

Typical Plate-Pulsed Operation

In Class B service at 540 MHz with a rectangular waveshape pulse, pulse width of 13, and duty factor of 0.003.

Peak Pulsed DC Plate Voltage	40,000	V
Peak Pulsed DC Grid No.2 Voltage.....	2,200	V
DC Grid No.1 Voltage ^{8,9}	-280	V
Peak Pulsed DC Plate Current	140	A
Peak Pulsed Grid No.2 Current	15	A
Peak Rectified Grid No.1 Current.....	10	A
DC Plate Current.....	0.60	A
DC Grid No.2 Current	0.06	A
DC Grid No.1 Current	0.04	A
Peak RF Drive Power (Approx.)	30,000	W
Useful Peak Power Output	3,000,000	W

RF Power Amplifier - Class C Telegraphy and Class C FM Telephony

Maximum CCS Ratings, Absolute-Maximum Values

For operation up to 550 MHz

DC Plate Voltage.....	13,000	V
DC Grid No.2 Voltage	1,400	V
DC Grid No.1 Voltage	-300	V
DC Plate Current	6.3	A
DC Grid No.1 Current	0.5	A
Grid No.2 input	750	W
Plate Dissipation	50,000	W

Typical CCS Operation

In Grid-Drive Circuit at 540 MHz.

DC Plate Voltage	12,000	V
DC Grid No.2 Voltage	1,000	V
DC Grid No.1 Voltage	-200	V
DC Plate Current.....	6.0	A
DC Grid No.2 Current	0.7	A
DC Grid No.1 Current	0	A
RF Drive Power	600	W
Useful Power Output	35,000	W

NOTES

- Emission, in excess of any requirements within tube ratings, is provided when the filament voltage is adjusted to its maximum specified value. To assure maximum tube life, the filament voltage should be adjusted and maintained at a value that will give adequate but not excessive emission. The filament voltage should be measured at the respective liquid coolant connections on the tube side of the threads. This procedure is essential for accurate measurement of the filament voltage.
- The tube coolant ducts must be free of water before storage or shipment of the tube to prevent damage from freezing.
- This pressure is related to the output cavity pressurization required to prevent corona or external arc-over.
- Measured directly across cooled element for the indicated typical flow.
- For protection recommendations see TP-105, Application Guide for BURLE Power Tubes.
- The peak pulsed DC value is defined as the maximum value of a smooth curve through the average of the fluctuations over the top portion of the pulse. The magnitude of any spike on the anode voltage shall not exceed the average peak pulse DC value by more than 4000 volts. The duration of any spike, when measured at its 70% point shall not exceed 2.0 microseconds.
The magnitude of any spike on the grid No.2 voltage shall not exceed the average peak pulse DC value by more than 250 volts. The duration of any spike when measured at its 70% point shall not exceed 2.0 microseconds.
- A maximum negative voltage of 300 volts may be applied to grid No.2 to prevent any tube conduction between pulses.
- For Class B operation, the negative grid No.1 voltage is between 1/5 and 1/8 of the peak pulsed DC grid No.2 voltage.
- The grid No.1 voltage may be a combination of fixed and self bias. The self bias may be obtained from a series grid resistor.

MECHANICAL CONSIDERATIONS

Mounting

The mounting should support the entire weight of the tube by either of the two cathode terminals. The tube can be secured in the circuit by suitable clamps, which engage the protruding part of the cathode terminal.

Connections

Flexible, spring contact connectors are required to establish good contact to the RF grid No.1 and the anode terminals. A compressible metal-braid gasket is recommended for making contact between each cathode terminal contact surface and its associated cavity.

Do not apply excessive force which might damage the ceramic bushings when attaching coolant connectors. Excessive stress may be prevented by gripping the flat edges of the coolant terminal with an open-end wrench when removing or tightening the mating coolant fitting.

Cooling Considerations

The tube is normally specified for use with the AJ2201 Coaxial Water Separator. This separator assures an adequate coolant flow with minimum pressure drop when connected in accordance with instructions. However, if lower anode dissipation is employed, satisfactory performance can be obtained with the more conventional AJ2290 Threaded Tube Water Separator available as a substitute for the AJ2201.

The AJ2290 provides convenient connections to the anode coolant courses. However for a given flow, it

produces a higher pressure drop than the AJ2201 Separator. Each coolant separator is shipped with an "O" ring and eight screws for attaching the separator to the tube. Before installation, wipe any dust particles from the "O" ring and coolant separator. Insert the "O" ring into the moat of the anode coolant course. Carefully insert the separator into the tube and secure it with the eight screws.

Plate Coolant Course Inspection

In order to prevent overheating, it is recommended that the tube operator periodically inspect the anode water course for copper oxide or other mineral deposits.

To inspect the anode coolant course (1) Remove the screws which secure the coolant separator. Lift the coolant separator carefully out of the tube. This assembly will come out easily unless there is an excessive deposit build up. If it doesn't come out easily, clean the anode coolant course* before making further attempts to remove the assembly; (2) Remove the "O" ring from the moat; (3) Inspect the internal structure of the anode coolant course with the aid of a convenient light. Determine if there is a flaky or adherent deposit on the structure. If such a deposit is observed it should be removed*. This deposit generally consists of copper oxide (usually black); (4) Replace the "O" ring in the moat. Orient the coolant separator assembly so that it is in its original position (refer to the index pin of the tube for orientation) and then seat it. Replace the screws. Tighten the screws in succession until snug.

* Cleaning procedures are outlined in TP-105; Applications Guide for BURLE Power Tubes.

ELECTRICAL CONSIDERATIONS

Mode of Operation

The BURLE 4664 is designed to operate in the TEM mode (transverse electromagnetic mode). It is free of spurious RF operating modes up to a frequency of approximately 500 MHz. Above this frequency some evidence of the $TE_{1,1}$ circumferential mode may be apparent. If this unwanted mode is observed, assistance in reducing or eliminating its effects can be obtained by contacting BURLE Application Engineering, 1000 New Holland Avenue, Lancaster, PA 17601-5688. This mode, if excited at the operating frequency will result in reduced power output and excessive anode and grid No.1 current at normal RF drive level.

The effects of the $TE_{1,1}$ circumferential mode* can be reduced or eliminated by shifting its resonant frequency. At BURLE, the circumferential mode frequency is shifted by using four trimmer anodes in the input cavity. These trimmer anodes are adjacent to the RF grid No.1 terminal as shown in the detail of Figure 2. Each anode is adjusted radially with a thumb screw for optimum operation, i.e., maximum power output and minimum Grid No.1 current. Once completed no further adjustment of the trimmers is required so long as the cavity tuning is not disturbed.

Driver

The value of driver power output given under Typical Ratings and Performance represents the approximate driving power required at the specified frequency. At high frequencies, more driving power may be necessary because of increased tube and circuit losses. In all cases, however, the driver stage should be designed to provide an excess of power over that indicated under the typical operating conditions to take care of variations in line voltage, components, initial tube characteristics, shifting tube characteristics during life, and transmission line mismatches.

REFERENCE

* R. W. P. King, H. R. Minno, and A. H. Wing, "Transmission Lines, Antennas, and Wave Guides" Published 1945 McGraw Hill Book Company, Inc.

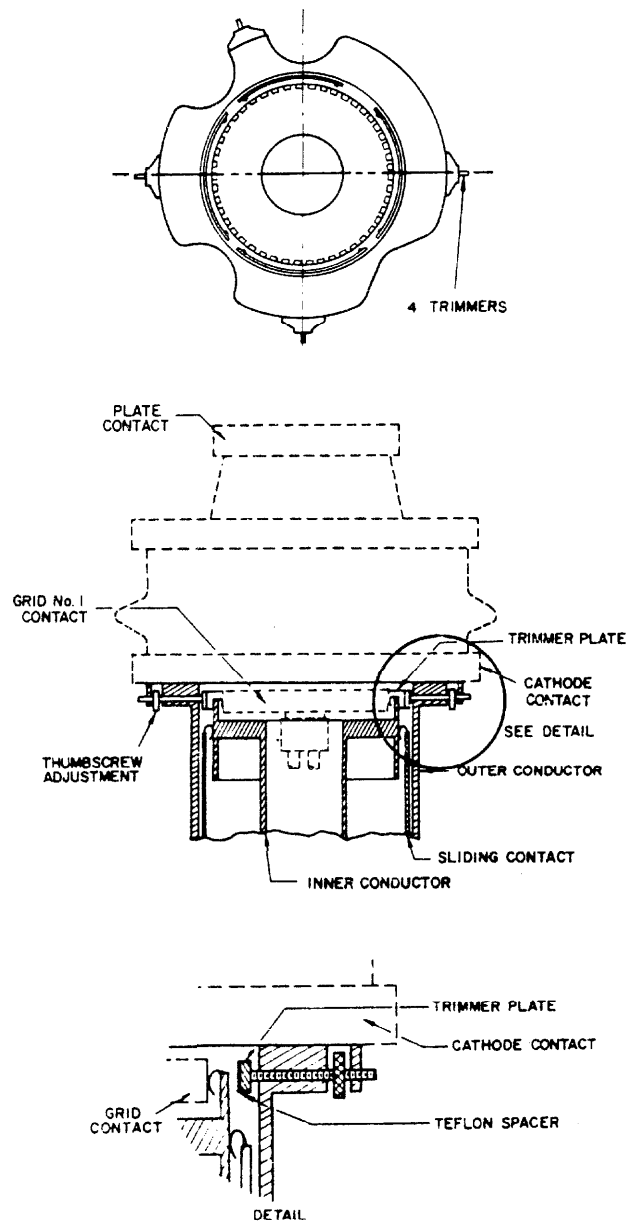

Figure 2: Input Cavity Section

Tabulated Dimensions

Dim.	Millimeters	Inches
A	355.6 ± 6.4	14.00 ± .30
C	85.3 ± 2.3	3.36 ± 0.09
D	150.6 ± 6.4	5.93 ± 0.25
E	47.8 ± 1.3	1.88 ± 0.05
F	29.7	1.17 Min
G	221.5 ± 0.8/-12.7	8.72 ± 0.03/-0.50 Dia.
H	199.90 ± 0.25	7.87 ± 0.01 Dia.
J	82.55	3.25 Rad.
K	15.0	0.59 Max
L	33	0.13
N	152.4	6.00 Max Dia.
P	31.75 ± 0.76	1.25 ± 0.03 Dia.
R	16.3 ± 1.3	0.64 ± 0.05
S	95.25 ± 0.25	3.750 ± 0.010 Dia.
T	25.4 ± 3.0/-0.8	1.00 ± 0.12/-0.8
U	22.6 ± 1.5	0.89 ± 0.06
V	285.8	11.25 Max
X	158.75	6.25 Dia.
Y	17.3	0.68 Max
AA		90°
AB	12.7	0.50 Min
AC	53.85 ± 0.76	2.125 ± 0.03
AD		0.41°
AE	103.1	4.06 Max Dia.
AF	36.6 ± 1.5	1.44 ± 0.06
AH	9.7	0.38 Min
AJ	125.7	4.95 Min Dia.
AK	15.49 + 0.51/-1.27	0.61 + 0.02/-0.05
AL	68.6	2.7
AM	2.3	0.09 Min
AN	6.3	0.25 Min
AP	96.77 ± 7.6	3.81 ± 0.30

Notes

- The dimensions in millimeters are derived from the basic inch dimensions (1 inch = 25.4 mm).
- Terminal has 1"-16 Unified Thread 2A fit, 0.38" (9.7 mm) long, and (2) holes 0.258"-0.270" (6.55-6.86 mm) diameter spaced 0.438" (11.13 mm) on centers.
- Pressure from circuit contacts should be exerted only over maximum length, AH, of designated contact areas of the plate or grid No. 1 terminals.
- This diameter dimension is held only over a length of AH.
- Dimension "L" applies over length AB and AN as indicated.
- The contact surfaces BA-BA' and BB-BB' of the RF cathode terminals will be parallel within 0.06" (1.5 mm).
- Contact of the input end RF cathode terminal should not be made at a diameter smaller than 4.06" (103.1 mm) nor greater than 4.95" (125.7 mm).
- To prevent excessive stress on the ceramic seal, a 15/16" open end wrench must be used to permit gripping the terminal when removing or tightening the coolant connectors.
- Contact of the output end RF cathode terminal should not be made at a diameter smaller than 6" (152 mm). The pressure exerted for this RF contact should be limited to that necessary for good electrical contact. The mechanical force for the cavity support and pressure seal should be made at a diameter not less than 6" (152 mm). On the output end RF cathode terminal, there are four equally spaced 0.188" (4.77 mm) diameter holes on a circle having a diameter of 6.75"

(171.4 mm). These holes are for tube manufacturing purposes only. Attention is called to the existence of these holes so that equipment designers can avoid making a pressure seal or electrical contact at points which are coincident with these holes. Mechanical clamping devices for the output cavity should be designed so as to exert their clamping force across outer edge of the output header flange.

- Serial number is located on this surface between DC Grid No. 2 and insulated filament terminal.
- Corners may be rounded or chamfered not to exceed 0.05" (1.3 mm).
- Keep this 5" (127 mm) diameter annular-volume region clear. Do not allow circuit components (conductors or insulators) to protrude into this region.
- The centers of the water course holes in each connection around the periphery of the tube shall be on a line through the center of these holes and perpendicular to the line through the center of the tube within ± 2°.

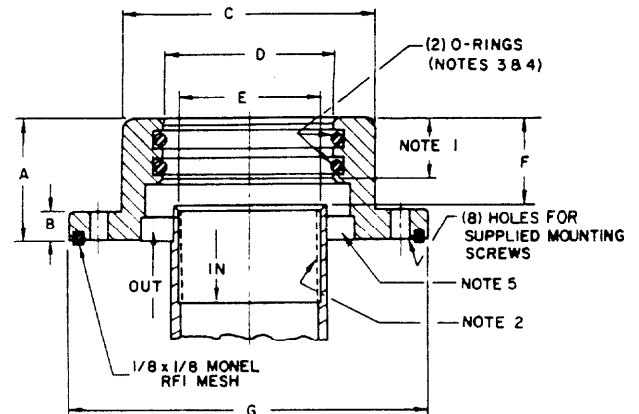

92LS - 3844

Tabulated Dimensions

Dimension	Millimeters	Inches
A	31.8 ± 0.8	1.25 ± 0.03
B	7.6 ± 0.8	0.30 ± 0.03
C Dia.	66.7 ± 0.4	2.625 ± 0.015
D Dia.	44.9 ± 0.4	1.768 ± 0.015
E Dia.	37.5 ± 0.4	1.475 ± 0.015
F	23.1 Max.	0.91 Max
G Dia.	95.2 Max.	3.75 Max.

Notes

- The outer coaxial tubing should penetrate 0.615" ± 0.010" (16.62 ± 0.25 mm) from the top surface.
- Diameter 'F' is polished over 0.80" (20.3 mm) length for coolant sealing by "O" ring.
- Buna N "O" Rings, (Uniform size 224) may be obtained from Garlock Packing Co., Parket seal Co., Precision Rubber Products Co.
- If a lubricant is desired for easier coolant tube insertion, a very light film of Dow Corning 4 Compound (MIL-S-8660B) or equivalent may be used. Dow Corning 4 Compound is manufactured by Dow Corning Corp., Midland, Michigan, U.S.A. All excess lubricant must be wiped off to prevent contamination of the coolant system.
- Four structural supports connect the sealing ring to the tubing.

Figure 4: Coaxial Coolant Separator - AJ2201

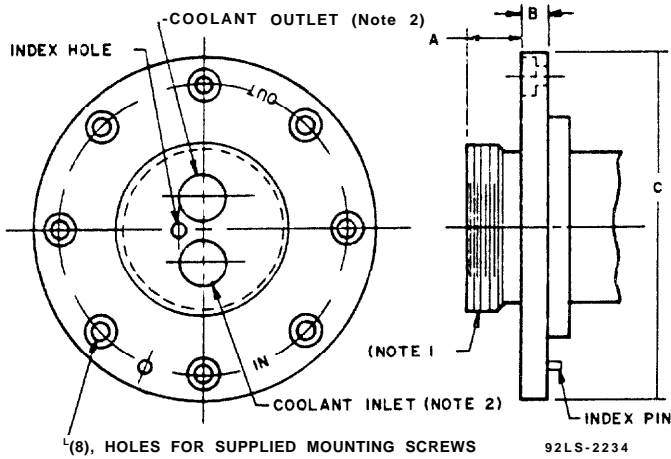

Tabulated Dimensions

Dim.	Millimeters	Inches
A	14.2 ± 1.0	0.56 ± 0.04
B	7.1 Max.	0.28 Max.
C Dia.	94.2 Max.	3.71 Max.

Notes

- Terminal has 1-3/4"-16 Unified Extra Fine Thread, Class 2A fit, 0.38" (9.65 mm) long, (2) holes 0.508"-0.522" (12.90" 13.26 mm) diameter, spaced 0.688" (17.48 mm) on centers and an index hole 0.160" (4.06 mm) maximum diameter spaced 0.344" (8.74 mm) from the center of the terminal.
- The holes in the anode coolant connection will accept the typical recommended anode coolant connection shown in Figure 6.

Figure 5: Threaded Coolant Separator — AJ2290

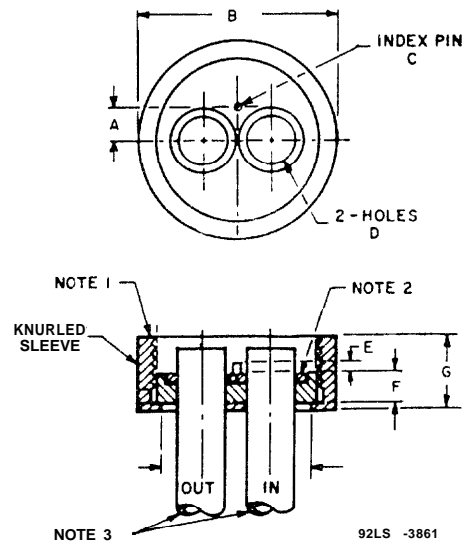

Tabulated Dimensions

Dim.	Millimeters	Inches
A	8.74	0.344
B Dia.	50.8	2.00
C Dia.	1.5	0.06
D Dia.	12.95	0.510
E	7.9	0.31
F	3.20	0.125
G	19.0	0.75
H Dia.	18.1	1.50

Notes

- Tapped 1-3/4"-16 UN-2B lass 2B.
- "Neoprene" or "Buna N" "O" Ring Gasket (Uniform size 112).
- 1/2" OD Copper Tubing to standard hose connection.
- Holes counterbored 0.687 (17.45) Dia. by 0.090 (2.29) deep and 0.688 (17.48) on centers.

Figure 6: Typical Anode Coolant Connection

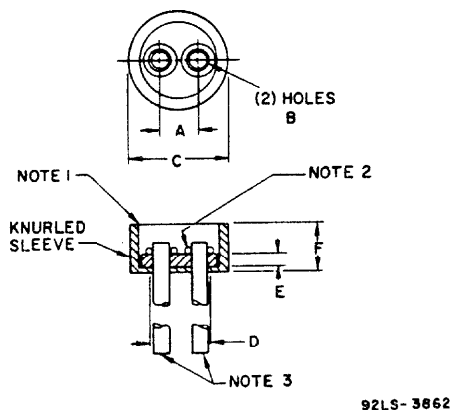

Tabulated Dimensions

Dimensions	Millimeters	Inches
A	(11.13)	0.438
B	(6.3) Dia. C'Bore 0.437 (11 .IO) Dia. x 0.057 (1.45) 0.250 deep	
C	(31.8) Dia.	1.25
D	(19.0) Dia.	0.75
E	(6.4)	0.25
F	(17.5)	0.69

Notes

- Tapped 1"-16 UN-2B x -0.50" (12.7 mm) deep.
- "Neoprene" or Buna N" "O" ring Gasket (Uniform size 011).
- 1/4" copper tubing to standard hose connection.

Figure 7: Typical Coolant Connection (Except Anode)

For additional information call 1-800-366-2875. In Europe call 44-93-276-5666

All specifications subject to change without notice. Information furnished by BURLE INDUSTRIES, INC. is believed to be accurate and reliable. However, no responsibility or liability is assumed by BURLE for its use, nor for any infringement of patents or other rights of third parties which may result from its use. No license is granted by implication or otherwise under any patent or other rights of BURLE INDUSTRIES, INC.

Copyright 1992 by BURLE TECHNOLOGIES, INC. All Rights Reserved.

BURLE[®] and BURLE INDUSTRIES, INC.[®] are registered trademarks of BURLE TECHNOLOGIES, INC. Marca(s) Registrada(s).

BURLE INDUSTRIES, INC., Tube Products Division, 1000 New Holland Avenue, Lancaster, PA 17601-5688 U.S.A.